

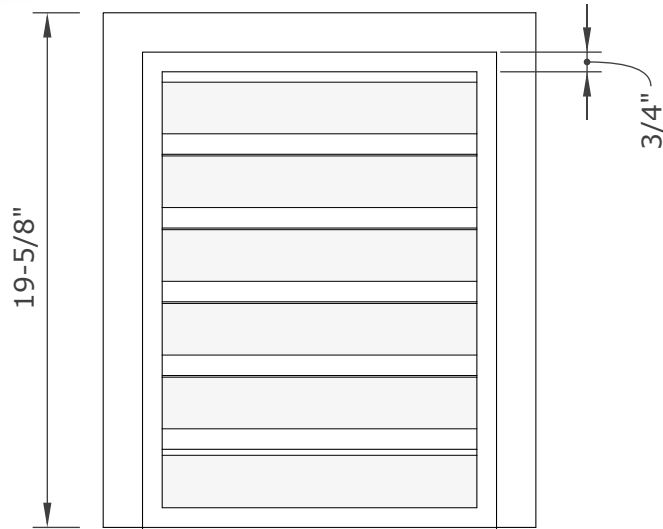

V2VENTS.COM (916) 652-7424 info@newcalmetals.com P.O. Box 1126 Loomis, CA. 95650

For use to comply with IWUI, IBHS Wildfire Prepared Certification, California Chapter 7A*



TOP VIEW

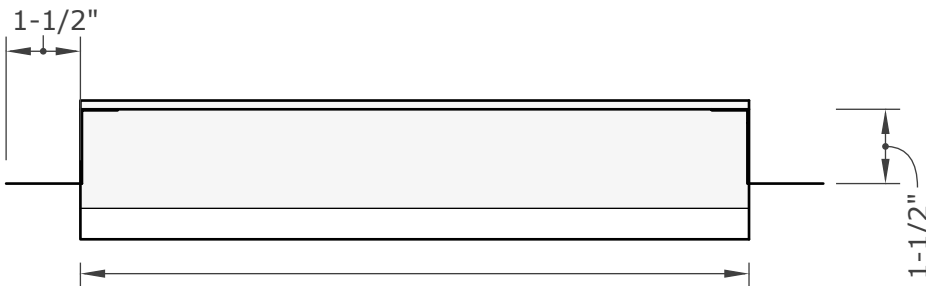

END VIEW

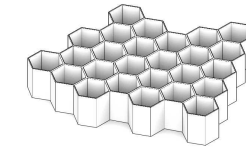

Intumescent Core

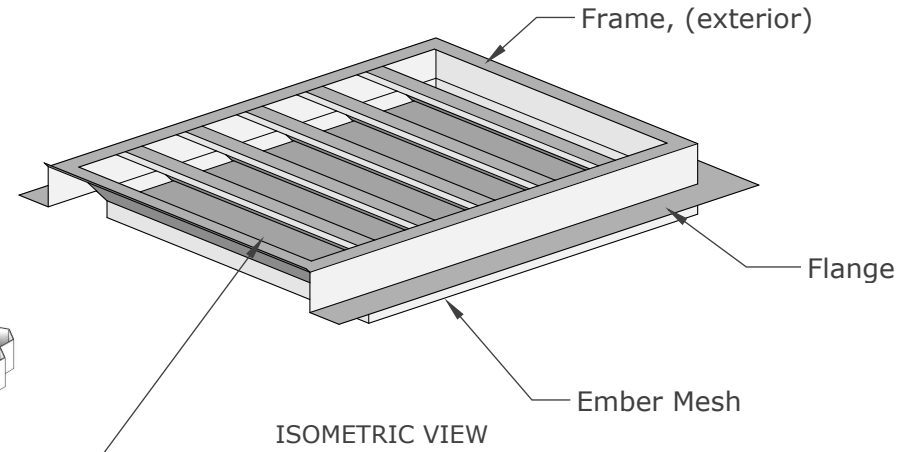

ISOMETRIC VIEW

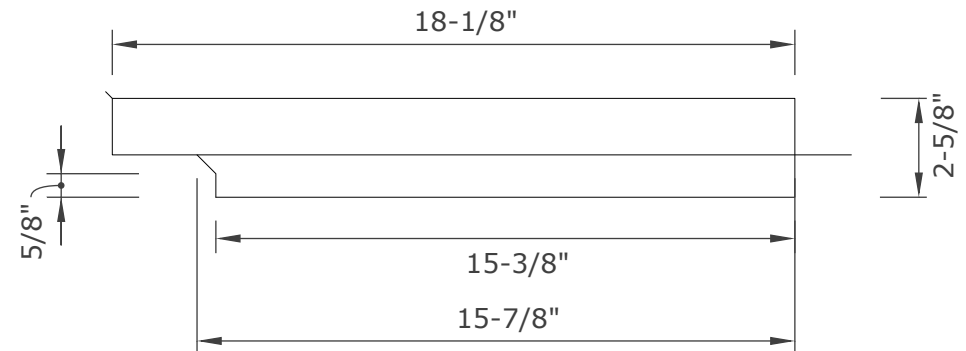

SIDE VIEW

Required Installation:

Use **EverKem 814+** intumescent firestop caulking or equivalent, BEHIND flanges.
For application details and installation examples, please visit www.V2Vents.com

FSVG1418FB PRODUCT SPECIFICATION & DATA SHEET

Proudly Manufactured By: **NEW CAL METALS INC.**

www.newcalmetals.com

Model Description	Gable Vent	Flange Type	Foam Back	Frame & Flange	G90 Galvanized Steel - 26GA
Model Number	FSVG1418FB	NFVA	86 sq. in.	Intumescent Core	5mm Hexagonal Matrix - Aluminum with intumescent coating
Model Size	13-5/8" x 18-1/2"			Ember Mesh	14 Mesh - 304 Stainless Steel