

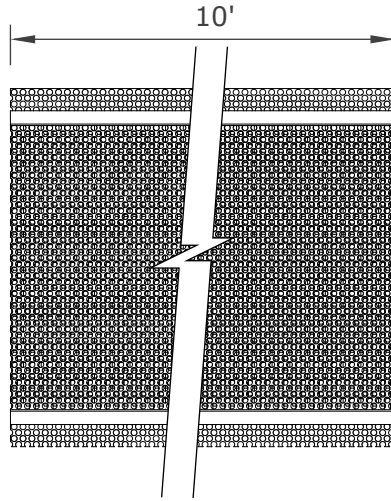

V2VENTS.COM (916) 652-7424 info@vulcanvents.com P.O. Box 1126 Loomis, CA. 95650

For use to comply with IWUI, IBHS Wildfire Prepared Certification, California Chapter 7A*



TOP VIEW

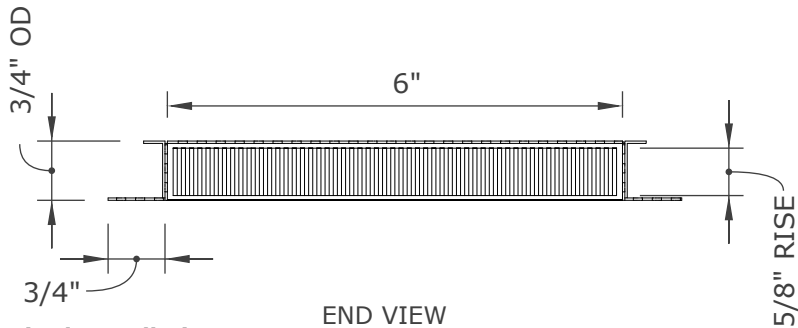

END VIEW

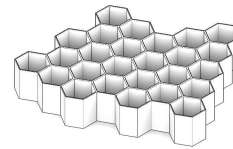

Intumescent Core

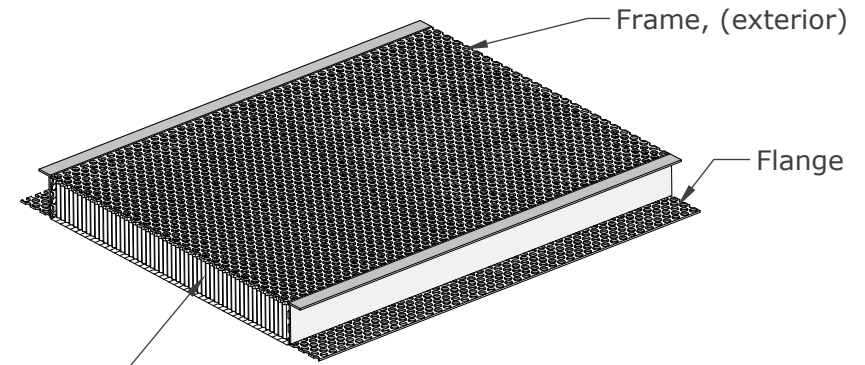

ISOMETRIC VIEWS

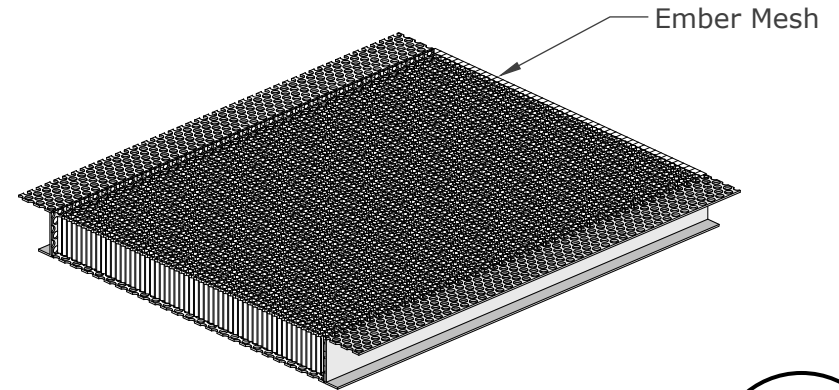

Required Installation:

Use **EverKem 814+ intumescent firestop caulking** or equivalent, BEHIND flanges.
For application details and installation examples, please visit www.V2Vents.com

Proudly Manufactured By: **NEW CAL METALS INC.**

www.newcalmetals.com

FSVSC6120SMC34 PRODUCT SPECIFICATION & DATA SHEET

| | | | | | |
|-------------------|------------------------|-------------|---------------------------|------------------|---|
| Model Description | Continuous Vent | Flange Type | Stucco MilCor 3/4" | Frame & Flange | G90 Galvanized Perforated Steel (1/8" holes) - 24GA |
| Model Number | FSVSC6120SMC34 | NFVA | 288 sq. in. | Intumescent Core | 5mm Hexagonal Matrix - Aluminum with intumescent coating |
| Model Size | 6" x 120" | | | Ember Mesh | 14 Mesh - 304 Stainless Steel |

